

5

FIXING INSTRUCTION FOR DOUBLE ACTION DOOR

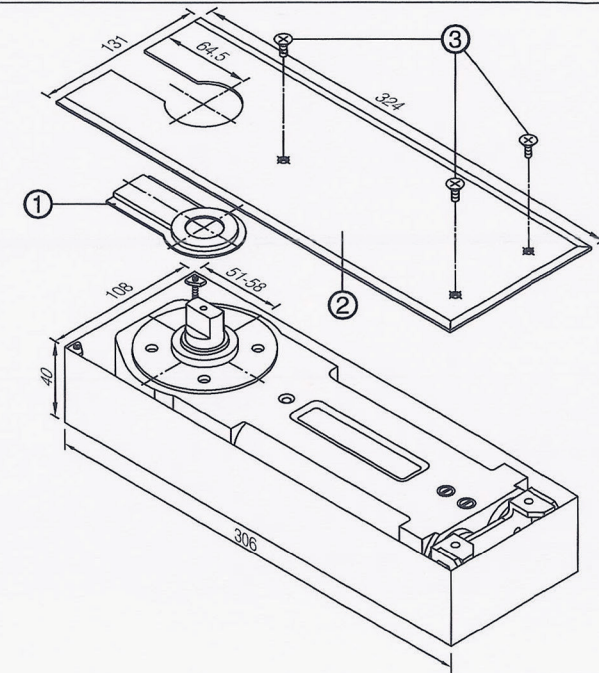
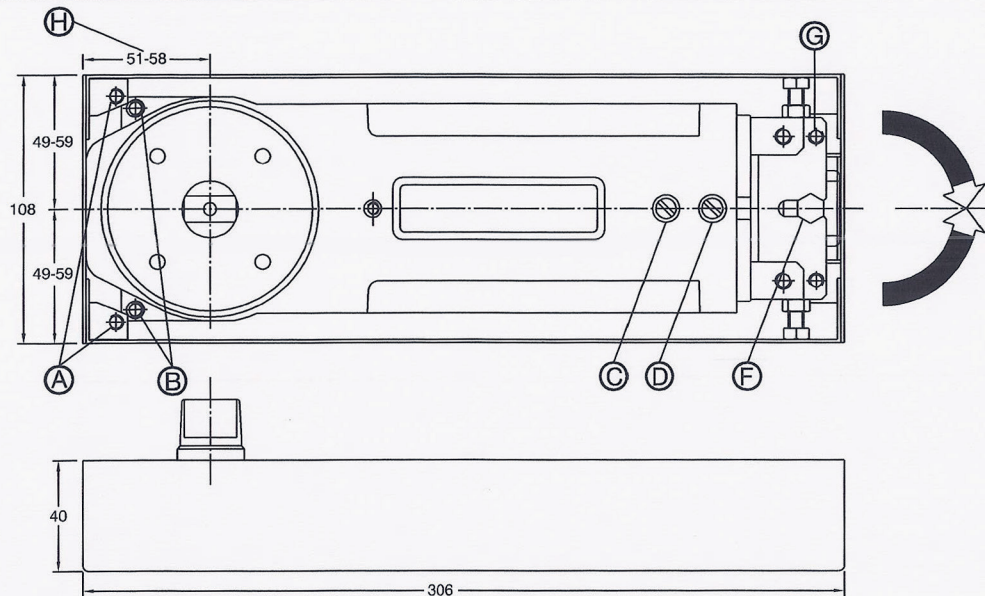

- A = Fixing screw
- B = Height adjustment screw
- C = Regulation valve 130°~10°
- D = Regulation valve 10°~0°
- F = Fixing screw
- G = Height adjustment screw
- H = Pivot centre

- 1 = Insert piece
- 2 = Cover plate
- 3 = Fixing screw M5x6

Adjustment in cement box

To adjust the position of floor spring in cement box, (7mm length x 10mm width x 4mm height) loosen fixing screws (A) and (F). Move floor spring to required position and use screws (B) and (G) for height adjustment. Retighten screws (A) and (F) after adjustment.

Centre hung doors

For centre hung doors, floor spring should be in the centre of cement box. Maximum door opening angle is 130° in each direction. For doors opening up to 130°, door stop MUST be fitted. Ensure that top centre is properly aligned with floor spring.

Adjustment of closing speed

Two regulating valves (C) and (D). (C) decrease closing speed, (D) increase closing speed.
 Valve C: controlled closing range 130°~10°.
 Valve D: controlled closing range 10°~0°.

Attachment of cover plate

Press insert piece (1) into gap behind spindle and secure cover plate (2) to floor spring with fixing screws (3).

FIXING INSTRUCTION FOR DOUBLE ACTION ALUMINIUM AND WOOD DOORS ACCESSORIES

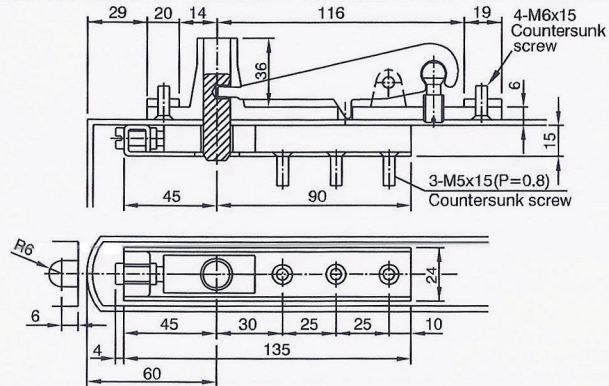
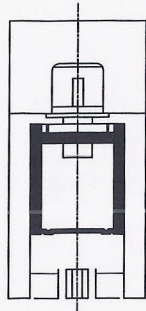

Ensure that top centre is properly aligned with floor spring

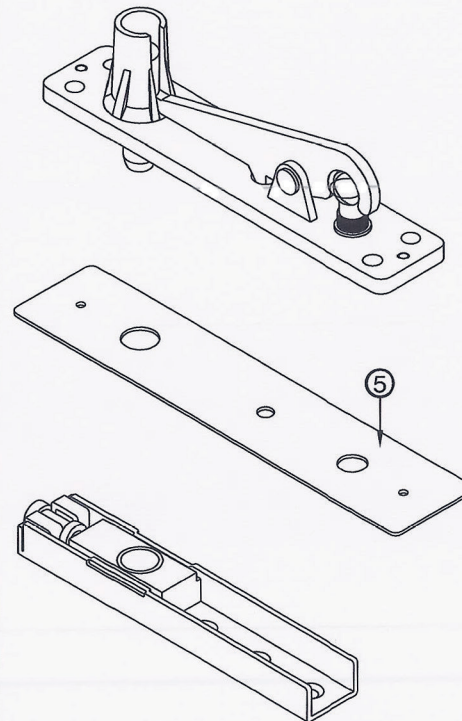
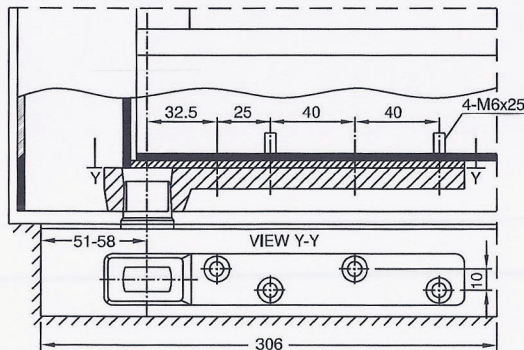
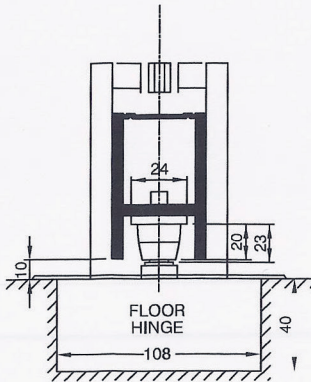

4. Installation of door

Bring door gently down onto floor spring; open door to gain access to top centre; lower pivot pin 3 into bearing by turning adjustment screw 1 clockwise. Ensure proper engagement of pivot pin into door portion of top centre.

5. Attachment of cover plate

Secure cover plate 5 to top centre frame portion by using two (2) M4x6 screws provided.

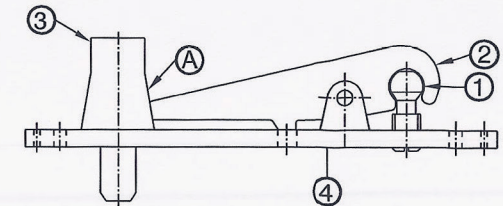

1. Preparation works

Mill or route door and frame to accept relevant top centre parts.



2. Top Centre - frame portion

To change the extended "throw" of the pivot pin 3 proceed as follows: Unscrew shoulder screw 4, turn adjustment screw 1 counter clockwise until pivot pin 3 and rocker arm 2 can be removed. Reassemble in pivot pin 3. Maximum "throw" is achieved with rocker arm 2 in position A.

3. Top Centre - door portion

Install pivot to door section as shown. Ensure that the top centre is properly aligned with floor spring.

Single Action Instructions

